

> We are DEVELON

We trace our roots to 1937 as one of Korea's first large scale machine plant. Throughout time we have consistently delivered exceptional products and solutions.

DEVELON is a bold name that reflects our core ambition to continue developing onwards and leaving behind a positive footprint in our world. Moving forward, we seek to be part of our customers and partners' endeavor to build a better world.

Powered by **Innovation**



©2023 HD Hyundai Infracore. All rights reserved.
HDIPBE-01-2305

develon-ce.com

Certain specification(s) are based on engineering calculations and are not actual measurements. Specification(s) are provided for comparison purposes only and are subject to change without notice. Specification(s) for your individual Develon equipment will vary based on normal variations in design, manufacturing, operating conditions, and other factors. Pictures of Develon units may show other than standard equipment.

DEVELON

Wheel Excavators

DX210WA

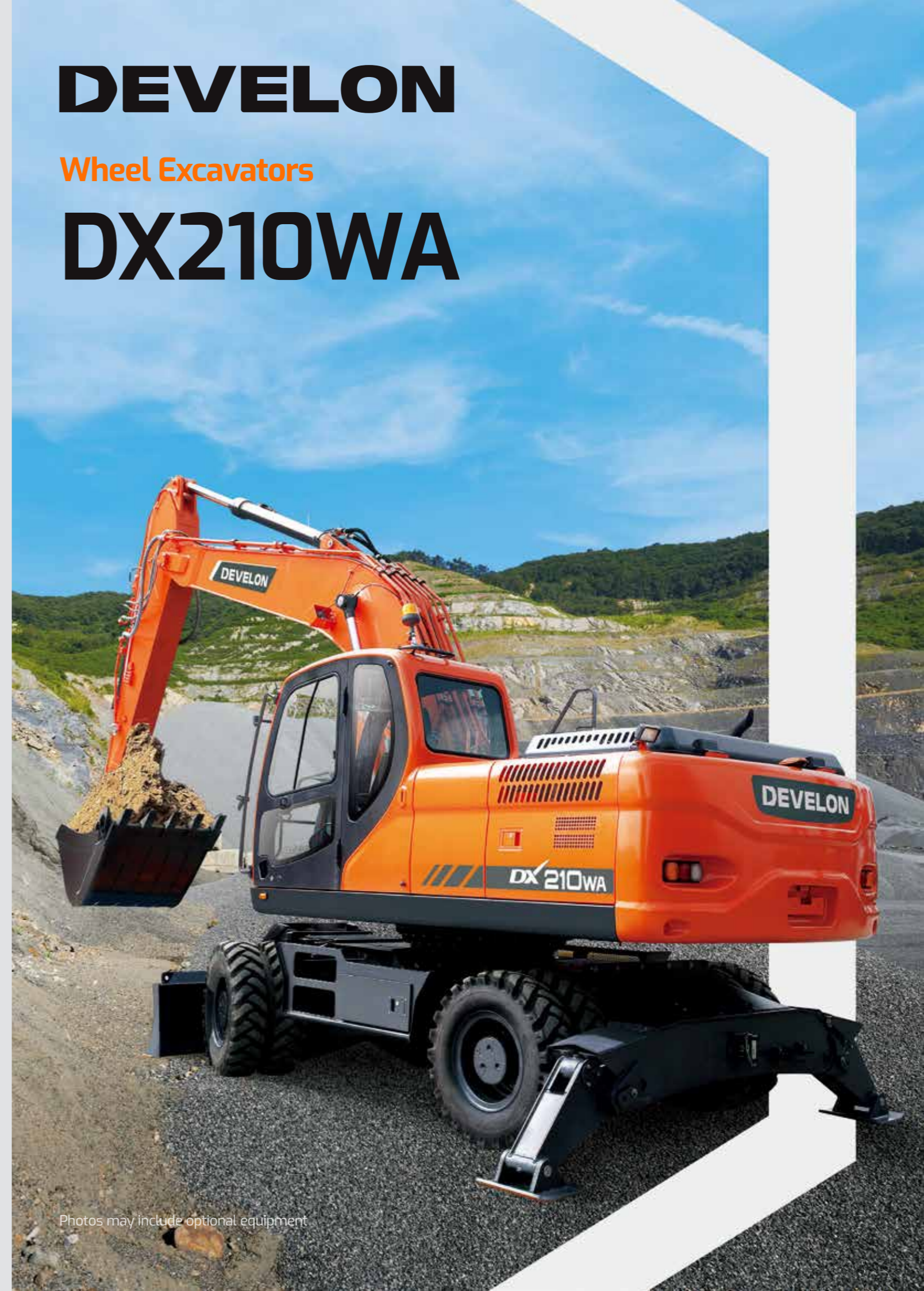

Photos may include optional equipment



High Fuel Efficiency with Excellent Quality, reliability & Durability.

DX210WA has been developed for the industry's No.1 fuel efficiency based on high durable components with great stability, engine power and swing torque

RELIABILITY

Durable components guarantee enough working hours without any down-time

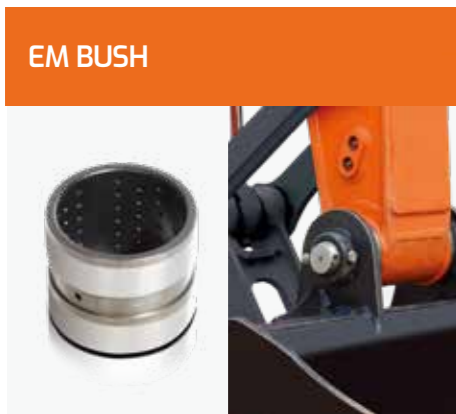

PERFORMANCE & STABILITY

SMOOTH SWING WITH INCREASED SWING TORQUE

- Develon in house engine perfectly harmonized with the hydraulic system and provides strong power.
- Mechanical engine providing high resistance to moisture, dust, and bad fuel quality.

DEVELON DX210WA ENGINE

Model	Develon DB58TIS 6-Cylinders
Type	Turbo charged
Rated Horse Power	163 PS @2,000 rpm (KS R1004) 120 kW (163 PS) @2,000 rpm (DIN 6271) 120 kW (160 HP) @2,000 rpm (SAE J1349)
Torque	70 kgf.m @ 1,400 rpm
Alternator	24 V x 60 A



SMOOTH SWING WITH INCREASED SWING TORQUE

New mottrol swing reduction gear minimizes shocks during rotation while making increased swing torque.



Swing Torque (kg.m)

6,418

67% UP

5,980

DX210WA

Previous Model

Bucket Cylinder

Arm Cylinder

Boom Cylinder & Swing Motor

The Industry's Best stability

- 3.8 ton Counter weight (The biggest)
- 2,850 Wheel based (The widest)

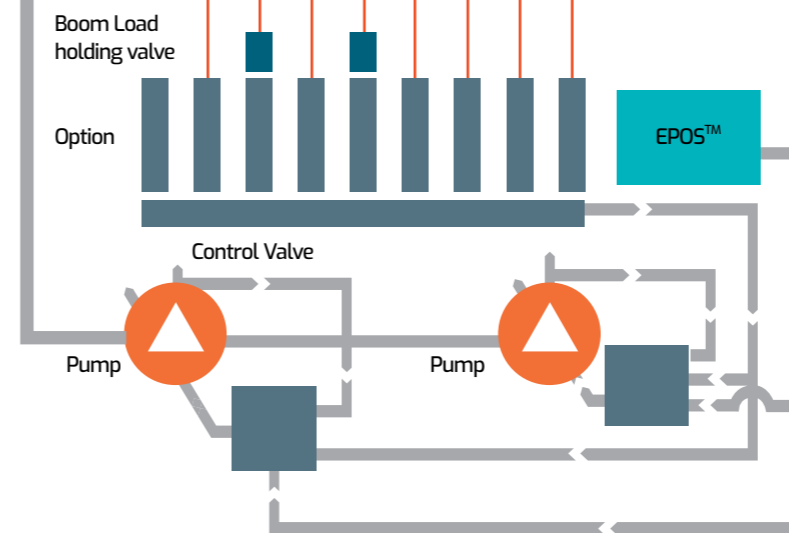

IMPROVED EXCAVATOR CONTROL BY NEW EPOS™ SYSTEM

The brains of the hydraulic excavator, the EPOS™ (Electronic Power Optimizing system), have been improved, through a CAN (Controller Area Network) communication link, enabling a continuous exchange of information between the engine and the hydraulic system.

The advantages of the new EPOS™ impacts at several levels, Ease of operation and user-friendliness:

- The availability of a power mode and standard mode guarantee maximum efficiency under all conditions.
- The automatic deceleration mode enables fuel saving.
- Regulation and precise control of the flow rate required by the equipment are available as standard.
- A self-diagnosis function enables technical problems to be resolved quickly and efficiently.
- An operational memory provides a graphic display of the status of the machine.
- Maintenance and oil change intervals can be displayed.

FUEL EFFICIENCY

RELIEF CUTOFF TO PREVENT TRANSFER OF UNNECESSARY FLOW

1. Typically, the pump tends to supply flow even when the maximum pressure on the system is reached due to severe working environments and large workloads.
2. Relief cutoff technology of Develon prevent transfer of unnecessary flow to keep powerful working level at the maximum value while reducing consumption of fuel.

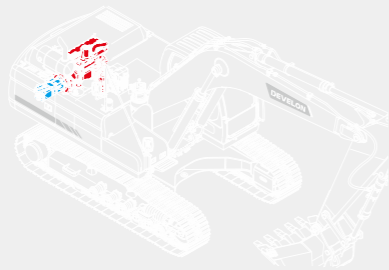

RELIEF CUTOFF

Relief cutoff technology saves 20~30% of fuel consumption in the heavy workload.



OPTIMIZED LEVER CONTROL & AUTO IDLE TO PREVENT UNNECESSARY FUEL CONSUMPTION

1. When operator takes break for rest with the joystick kept fixed, both of the engine and the pump are kept in standby mode with maximum rotation rate and hydraulic power. In such a case, unnecessary fuel consumption takes place.
2. The auto idle technology effectively controls the engine, and prevents unnecessary fuel consumption while the engine is kept in standby mode. Further, the optimized lever control technology effectively controls the pump to keep power of the pump maximum and prevent fuel consumption while the system is kept shut down.
3. When operating the joystick, rotation rate of the engine and maximum hydraulic power of the pump increase simultaneously for efficient consumption of fuel. The technologies of Develon enable operation of the system with maximum power in time.

OPTIMIZED LEVER CONTROL

In auto idle, you can save 90% of fuel than in operation.

Fuel consumption in operation

Fuel consumption in auto idle



ENGINE & PUMP MATCHING TO REDUCE MATCHING RESPONSE TIME OF THE SYSTEM

1. It is common that response time of the system (time for generating rated power from the minimum power) is slower than response speed of the pump. In such a case, the pump is kept in standby mode until the engine reaches the rated power to cause unnecessary fuel consumption. In addition, more fuel is supplied to the engine for matching the pump speed with the engine to result in more exhaust fumes.
2. Engine & pump matching, the new technology of Develon, fully resolves these problems. Matching response time between pump and engine efficiently reduces unnecessary fuel consumption as well as exhaust fumes.

ENGINE & PUMP MATCHING

Matching response time between pump and engine makes higher performance with reduced fuel consumption.

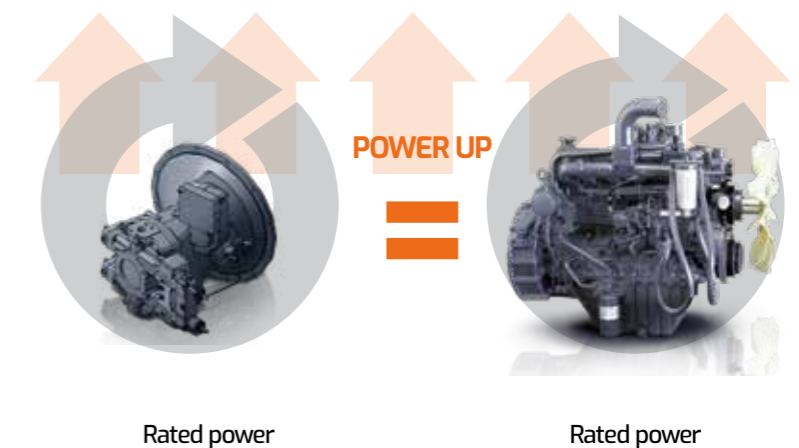

**MARKET NO.1 FUEL EFFICIENCY IN
MIDDLE WHEEL EXCAVATOR.**

“NEW CONTROL LOGIC” FOR BETTER FUEL EFFICIENCY



FUEL EFFICIENCY

**↑ 13%
BETTER**

FUEL CONSUMPTION

**↓ 13%
SAVING**

HANDLING & COMFORT



1. CELLULAR PHONE BOX

2. STORAGE SPACE



3. AIR CONDITIONING WITH CLIMATE CONTROL

The High performance, electronically controlled air conditioning features 5 different operating modes allowing the operator to adjust the airflow to suit conditions. A re-circulated air function is also available. Temperature is adjustable from 17°C (62°F) to 32°C (90°F) by 0.5°C (1°F) increments.

4. STEERING COLUMN

The Forward/Neutral/Reverse & gear selection switch is mounted on the steering column to minimize operator movements while traveling so that safety and operator comfort are ensured. The lower part of Steering Column can be tilted for improved operator comfort.



5. DOZER/OUTRIGGER CONTROL

The dozer/outrigger control lever, combined with the associated switches, allows for the operator to select between any combination of independent or simultaneous operation of the dozer/outriggers.



6. CONTROL PANEL

The control panel is clear, simple to read and positioned for easy use, allowing you to work safely and confidently.



7. THIRD GEAR SPEED CONTROLLER

8. REAR-VIEW CAMERA



9. 7 INCH MONITOR

- Gauges
- Navigation modes
- Rear view camera
- Display selector
- Working modes
- Auto-idle & flow rate control

10. AIR SUSPENSION SEAT (OPTIONAL)

An air suspension seat is available as an option, which further reduces any vibration being transmitted to the operator while working or travelling. In addition, this option is fitted with a heating system for operator comfort in cold weather.





MAINTENANCE & SAFETY



CONVENIENT FUSE BOX

The fuse box is conveniently located in a section of the storage compartment behind the operator's seat providing a clean environment and easy access.

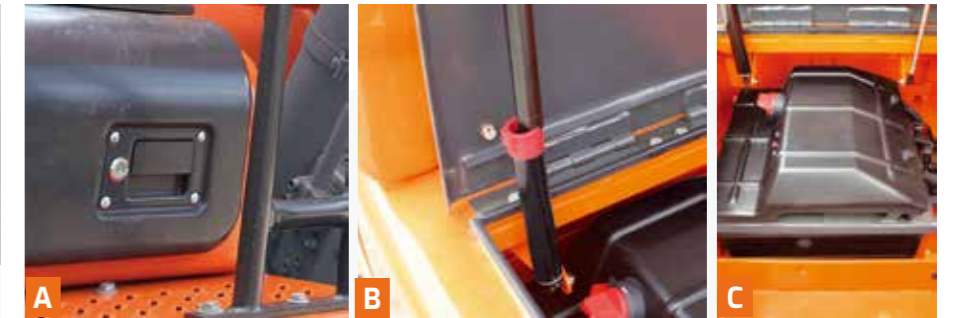

NEW BATTERY BOX

A. Cut-off switch easier to reach
 B. New spring to facilitate fixing
 C. New locking device



HYDRAULIC OIL RETURN FILTER

The protection of the hydraulic system is more effective, using glass fiber filter technology in the main oil return filter. This means that with more than 99.5% of foreign particles filtered out, the oil change interval is increased.

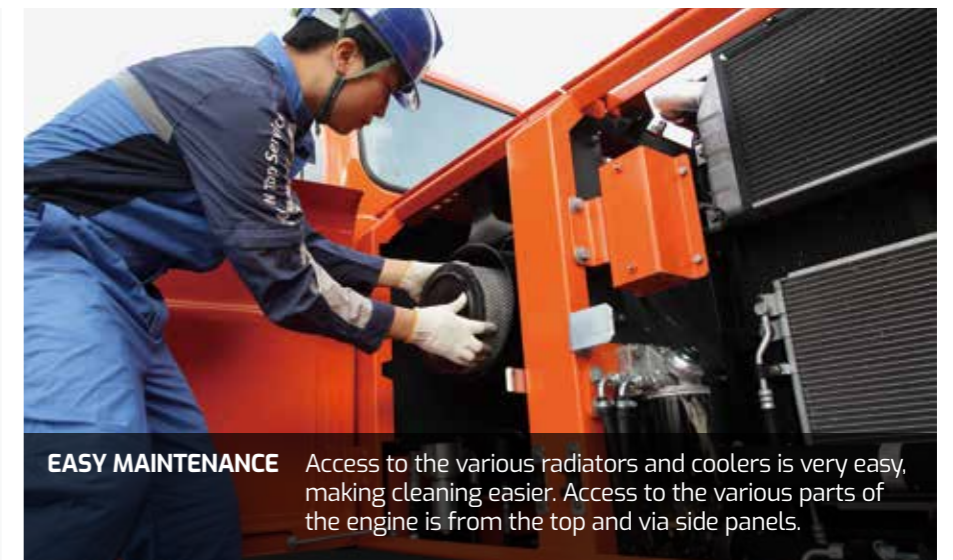

EASY MAINTENANCE Access to the various radiators and coolers is very easy, making cleaning easier. Access to the various parts of the engine is from the top and via side panels.



FUEL PRE-FILTER

High efficiency fuel filtration is attained by the use of multiple filters, including a fuel prefilter fitted with a water separator that removes most moisture from the fuel.



AIR CLEANER

The large capacity forced air cleaner removes over 99% of airborne particles, reducing the risk of engine contamination and making the cleaning and cartridge change intervals greater.



REMOTE GREASING POINTS

For comfortable maintenance, the arm and boom greasing points have been centralised. Remote & grouped greasing points on boom & arm.



PC MONITORING

A PC monitoring function enables connection to the e-EPOS system. Thus, various parameters can be checked during maintenance, including pump pressures, engine rotation and engine speed. These can be stored and printed for analysis.



LARGER ANTI-SLIP SURFACE

High friction coefficient guarantees user's safety while maintaining main parts in wet condition.

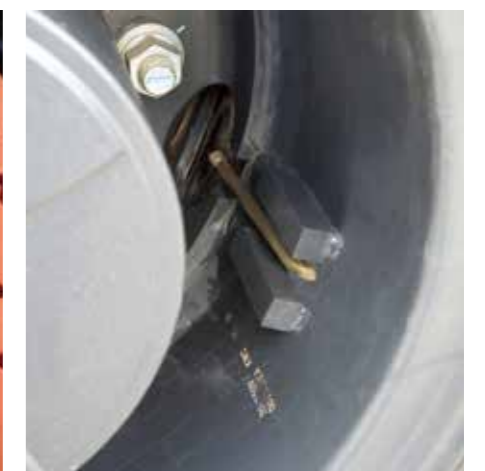

IMPROVED RIM & RUBBER SPACE

New type Rim makes it possible to inject air from outside of machine. And expanded rubber space increases safety for maintenance.

TECHNICAL SPECIFICATION

ENGINE

Model

DB58TIS
2 valves per cylinder, vertical injectors, water cooled, turbo charged with air to air intercooler. The emission levels are well below the values required for Tier II.

Number of cylinders

6

Rated Horse Power

163 PS @ 2,000 rpm (KS R1004)
120 kW (163 PS) @ 2,000 rpm (DIN 6271, Gross)
120 kW (160 HP) @ 2,000 rpm (SAE J1349, Net)

Max torque

70 kgf.m @ 1,400 rpm

Piston displacement

Ø102 mm X 118 mm

Starter

24 V / 4.5 kW

Batteries

2 X 12 V / 150 Ah

Air cleaner

Double element with auto dust evacuation.

HYDRAULIC CYLINDERS

The piston rods and cylinder bodies are made of high-strength steel. A shock absorbing mechanism is fitted in all cylinders to ensure shock-free operation and extend piston life.

Cylinders	Quantity	Bore x Rod diameter x stroke
Boom	2	120x 85 x 1,225 mm(4.7"X3.3"X4')
Arm	1	135 x 95 x 1,450 mm(5.3"X3.7"X4'9")
Bucket	1	120 x 80 x 1,060 mm(4.7"X 3'2"X 3'6")

ENVIRONMENT

Noise levels comply with environmental regulations (dynamic values).

LWA EXTERNAL SOUND LEVEL

106 dB (A) (2000/14/EC)

LPA OPERATOR SOUND LEVEL

75 dB (A) (ISO 6396)

WEIGHT

Operating weight including Boom, Arm, Bucket, Undercarriage attachment, operator, lubricant, coolant, full fuel tank and the standard Bucket equipment.

Front Combination		Undercarriage Type		Operating Weight
Boom (mm)	Arm (mm)	Front	Rear	
5,600	2,750	Dozer	Outrigger	19,900 kg / 20,000 kg (43,891 lb / 44,092 lb)
5,600	3,000	Dozer	Outrigger	20,800 kg / 20,910 kg (45,856 lb / 46,099 lb)
5,400 (Two-Piece)	2,400	Outrigger	Outrigger	20,600 kg / 20,720 kg (45,415 lb / 45,680 lb)

HYDRAULIC SYSTEM

The heart of the system is the EPOS™ (Electronic Power Optimizing System). It allows the efficiency of the system to be optimized for all working conditions and minimizes fuel consumption. The new EPOS™ is connected to the engine electronic control via a data transfer link to harmonize the operation of the engine and hydraulics.

- The hydraulic system enables independent or combined operations
- Cross-sensing pump system for fuel savings.
- Auto deceleration system.
- Two operating modes, two power modes.
- Button control of flow in auxiliary equipment circuits.
- Computer-aided pump power control.

Main pumps

2 variable displacement axial piston pumps
max flow: 2 x 231.7ℓ/min (2 X 61.21 US gpm, 2 X 50.97 lmp gpm)

Pilot pump

Gear pump - max flow: 27.4ℓ/min (7.24 US gpm, 6.03 lmp gpm)

Maximum system pressure

Boom/arm/Bucket:

- Normal mode: 330 kgf/cm² (324 bar)
- Power mode: 350 kgf/cm² (343 bar)
- Travel: 350 kgf/cm² (343 bar)
- Swing: 270 kgf/cm² (265bar)

SWING MECHANISM

- An axial piston motor with two-stage planetary reduction gear is used for the swing.
- Increased swing torque reduces swing time.
- Internal induction-hardened gear.
- Internal gear and pinion immersed in lubricant bath.
- The swing brake for parking is activated by spring and released hydraulically.

Swing speed : 0 to 11 rpm

UNDERCARRIAGE

Heavy-duty frame, all-welded stress-relieve structure. Top grade materials used for toughness. Specially heat-treated connecting pins. 10.0-20-16PR double tires with tire spacer. Front axle oscillating hydraulically.

DRIVE

Fully hydrostatic driven, 3 speed power shift transmission, variable displacement, high torque, axial piston motor, foot pedal controls provide smooth travel, hub reduction type front steering axle and rear rigid axle.

Travel speed

36 km/h (23 mph)

Maximum traction force

12,325 kgf (27,172 lbf)

Maximum grade

31°/ 60 %

REFILL CAPACITIES

Fuel tank

350ℓ (92.46 US GAL, 76.99 IMP GAL)

Cooling system (Radiator capacity)

24ℓ (6.34 US GAL, 5.28 IMP GAL)

Engine oil

26ℓ(6.87 US GAL , 5.73 LMP GAL)

Swing drive

5 L (1.32 US gal)

Hydraulic tank

205ℓ(54.16US GAL, 45.09 IMP GAL)

DIGGING FORCES (SAE)

DX210WA	Unit	Boom : 5,600 mm Arm : 3,000 mm	Boom: 5,600 mm Arm: 2,750 mm	Boom: 5,600 mm Arm: 2,400 mm
Bucket	t	12.5	12.5	12.5
Arm	t	9.3	9.7	10.8

BUCKET

Bucket Type	Capacity		Width		Weight	5.6m Boom			Arti Boom (5.4m)
	SAE/PCSA	CECE	W/O Cutter	With Cutter		2.4m Arm	2.75m Arm	3.0m Arm	2.4m Arm
GP	0.51 m ³	0.47 m ³	722 mm	778 mm	549 kg	A	A	A	A
	0.81 m ³	0.72 m ³	1,065 mm	1,134 mm	683 kg	A	A	B	A
	0.86 m ³	0.76 m ³	1,117 mm	1,180 mm	695 kg	A	B	B	A
	1.05 m ³	0.92 m ³	1,309 mm	1,378 mm	776 kg	C	C	D	B
	1.17 m ³	1.00 m ³	1,430 mm	1,499 mm	835 kg	C	D	D	C
	1.28 m ³	1.10 m ³	1,544 mm	1,613 mm	872 kg	D	D	-	D
H Class	0.60 m ³	0.56 m ³	750 mm	N/A	651 kg	A	A	A	A
	0.76 m ³	0.69 m ³	900 mm	N/A	722 kg	A	A	A	A
	0.92 m ³	0.83 m ³	1,050 mm	N/A	831 kg	B	C	C	B
	1.08 m ³	0.97 m ³	1,200 mm	N/A	884 kg	C	D	D	C
	1.24 m ³	1.11 m ³	1,350 mm	N/A	955 kg	D	D	-	D
	1.35 m ³	1.20m ³	1,450 mm	N/A	1,023 kg	-	-	-	D
	1.40 m ³	1.24 m ³	1,500 mm	N/A	1,064 kg	-	-	-	-
1.51 m ³	1.34 m ³	1,600 mm	N/A	1,114 kg	-	-	-	-	

A : Suitable for materials with density of 2,000kg/m³ (3,370lb/cu.yd) or less
B : Suitable for materials with density of 1,600kg/m³ (2,690lb/cu.yd) or less
C : Suitable for materials with density of 1,100kg/m³ (1,850lb/cu.yd) or less

DIMENSIONS

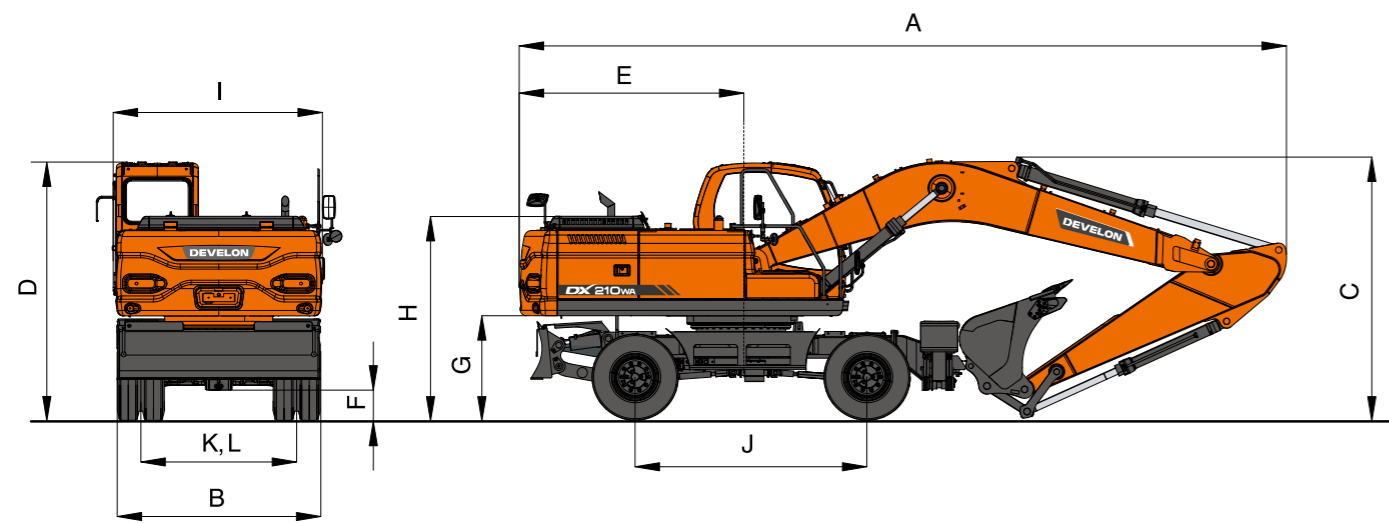

Reference	Description	5.6 m One-Piece Boom		
		3.0 m Arm	2.75 m Arm	2.4 m Arm
A	Shipping Length	9,400 mm	9,420 mm	9,470 mm
B	Shipping Width	2,500 mm	←	←
C	Shipping Height(Boom)	3,490 mm	3,200 mm	3,200 mm
D	Height Over Cab	3,140 mm	←	←
E	Counter Weight Swing Clearance	2,750 mm	←	←
F	Ground Clearance	350 mm	←	←
G	Counter Weight Clearance	1,259 mm	←	←
H	Engine Cover Height	2,485 mm	←	←
I	Upper Housing Width	2,530 mm	←	←
J	Wheelbase	2,850 mm	←	←
K, L	Tread Width	1,914 mm	←	←

WORKING RANGES

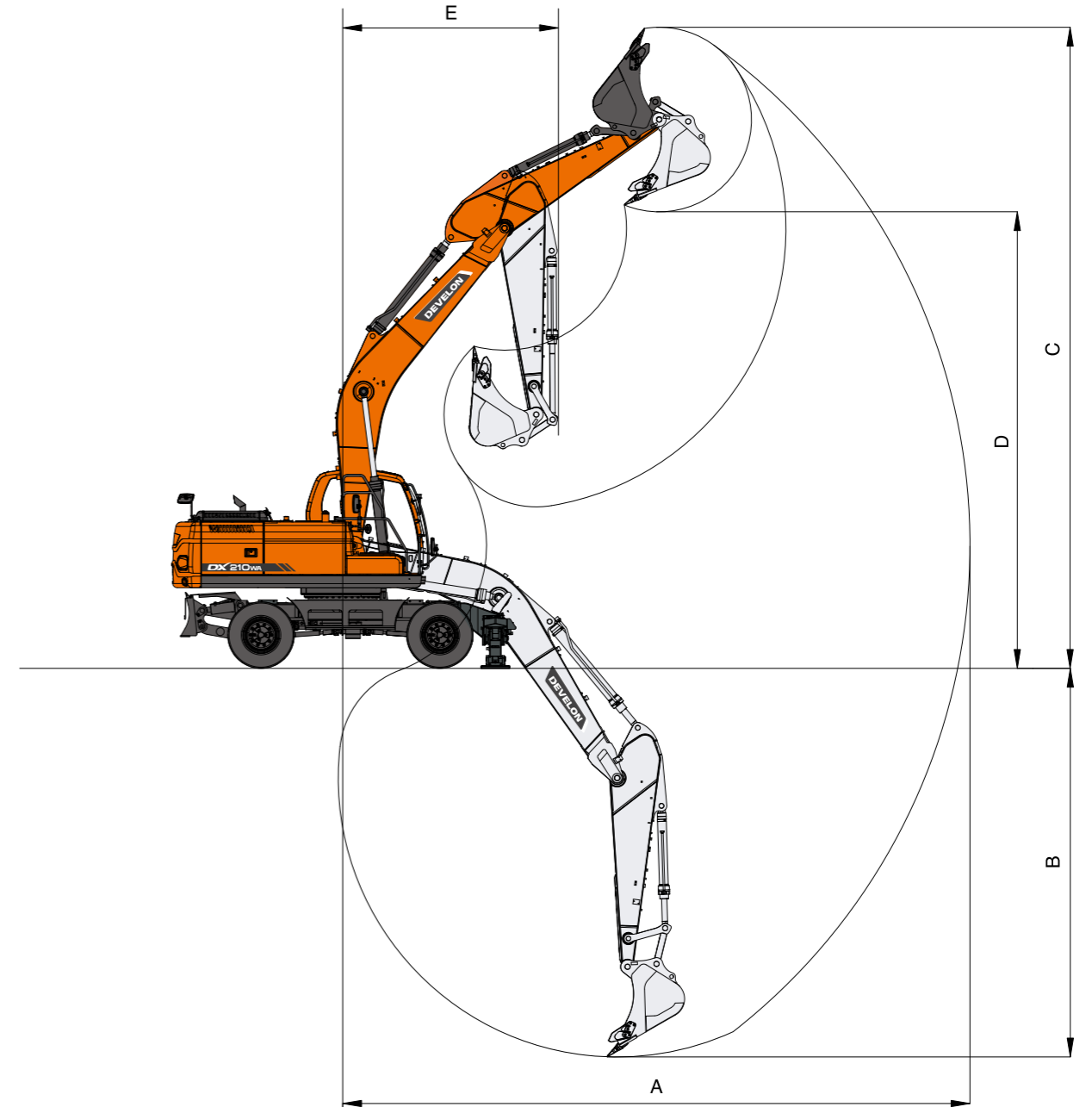

Reference	Description	5.6 m One-Piece Boom (mm)		
		3.0 M ARM	2.75 M ARM	2.4 M ARM
A	Max. Digging Radius	10,000	9,730	9,430
B	Max. Digging Depth	6,255	6,010	5,655
C	Max. Digging Height	10,050	9,800	9,690
D	Max. Dump Height	7,250	7,020	6,890
E	Min. Swing Radius	3,440	3,375	3,390

LIFTING CAPACITY

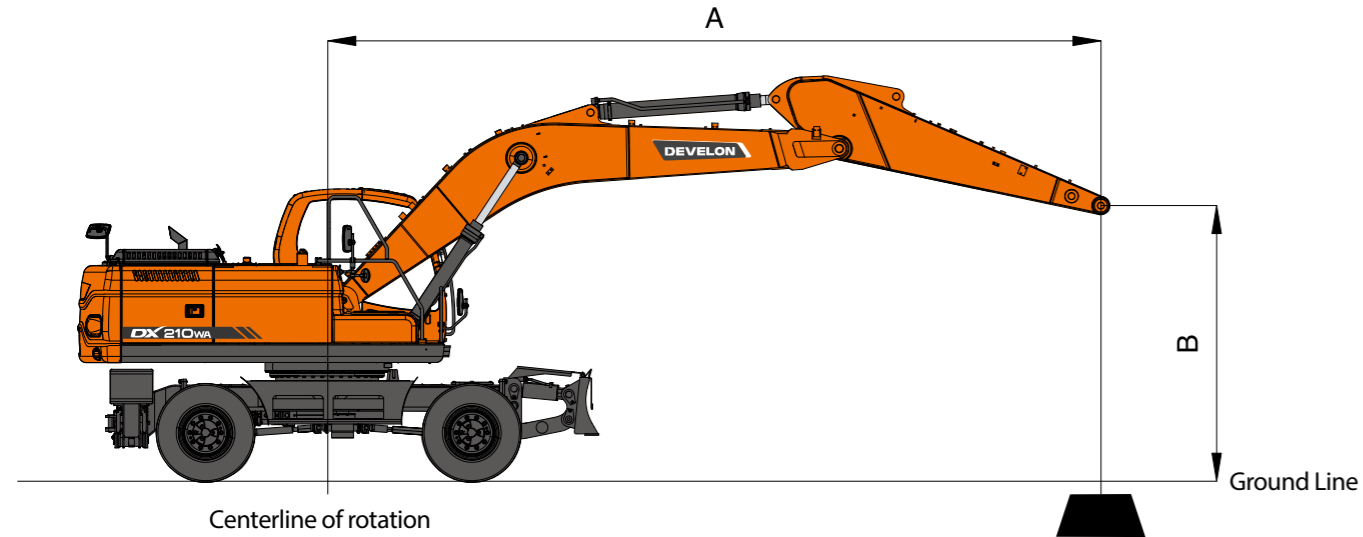

STANDARD

Boom : 5.6 m (18'04") One-Piece Boom Arm : 3.0 m (9'10") Bucket : Without Bucket Counterweight : 3,800 kg

Metric

Unit : 1,000kg

A(m) B(m)	Classis Frame Attachment	2		3		4		5		6		7		8		Max. Reach			
																		A(m)	
8	F-Dozer + R-Outrigger																*5.41	*5.41	5.66
	F-Outrigger + R-Outrigger																*5.41	*5.41	5.66
7	F-Dozer + R-Outrigger									*5.18	*5.18						*5.19	*5.19	6.60
	F-Outrigger + R-Outrigger									*5.18	*5.18						*5.19	*5.19	6.60
6	F-Dozer + R-Outrigger									*5.24	*5.24	*5.18	*5.18				*5.12	*5.12	7.28
	F-Outrigger + R-Outrigger									*5.24	*5.24	*5.18	*5.18				*5.12	*5.12	7.28
5	F-Dozer + R-Outrigger							*5.94	*5.94	*5.54	*5.54	*5.28	*5.28				*5.15	4.68	7.76
	F-Outrigger + R-Outrigger							*5.94	*5.94	*5.54	*5.54	*5.28	*5.28				*5.15	4.72	7.76
4	F-Dozer + R-Outrigger			*10.16	*10.16	*7.90	*7.90	*6.72	*6.72	*6.00	*6.00	*5.53	5.44	*5.24	4.44	*5.22	4.36	8.09	
	F-Outrigger + R-Outrigger			*10.16	*10.16	*7.90	*7.90	*6.72	*6.72	*6.00	*6.00	*5.53	5.49	*5.24	4.48	*5.22	4.40	8.09	
3	F-Dozer + R-Outrigger			*7.11	*7.11	*9.49	*9.49	*7.60	*7.60	*6.53	*6.53	*5.84	5.37	*5.37	4.40	*5.27	4.17	8.29	
	F-Outrigger + R-Outrigger			*7.11	*7.11	*9.49	*9.49	*7.60	*7.60	*6.53	*6.53	*5.84	5.41	*5.37	4.44	*5.27	4.21	8.29	
2	F-Dozer + R-Outrigger					*10.86	*10.86	*8.43	*8.43	*7.04	6.64	*6.15	5.29	*5.53	4.36	*5.34	4.09	8.36	
	F-Outrigger + R-Outrigger					*10.86	*10.86	*8.43	*8.43	*7.04	6.70	*6.15	5.34	*5.53	4.40	*5.34	4.13	8.36	
1	F-Dozer + R-Outrigger			*2.72	*2.72	*11.67	*11.67	*9.04	8.61	*7.44	6.53	*6.39	5.22	*5.64	4.32	*5.43	4.09	8.31	
	F-Outrigger + R-Outrigger			*2.72	*2.72	*11.67	*11.67	*9.04	8.68	*7.44	6.59	*6.39	5.27	*5.64	4.36	*5.43	4.13	8.31	
0	F-Dozer + R-Outrigger			*4.69	*4.69	*11.90	*11.90	*9.33	8.50	*7.67	6.46	*6.52	5.17	*5.63	4.29	*5.52	4.20	8.13	
	F-Outrigger + R-Outrigger			*4.69	*4.69	*11.90	*11.90	*9.33	8.58	*7.67	6.52	*6.52	5.22	*5.63	4.33	*5.52	4.24	8.13	
-1	F-Dozer + R-Outrigger	*4.40	*4.40	*7.28	*7.28	*11.67	*11.67	*9.30	8.45	*7.66	6.42	*6.46	5.15			*5.60	4.42	7.82	
	F-Outrigger + R-Outrigger	*4.40	*4.40	*7.28	*7.28	*11.67	*11.67	*9.30	8.52	*7.66	6.48	*6.46	5.20			*5.60	4.46	7.82	
-2	F-Dozer + R-Outrigger	*7.36	*7.36	*10.52	*10.52	*11.05	*11.05	*8.94	8.44	*7.38	6.41	*6.12	5.15			*5.67	4.82	7.36	
	F-Outrigger + R-Outrigger	*7.36	*7.36	*10.52	*10.52	*11.05	*11.05	*8.94	8.52	*7.38	6.47	*6.12	5.20			*5.67	4.86	7.36	
-3	F-Dozer + R-Outrigger	*10.73	*10.73	*12.44	*12.44	*10.01	*10.01	*8.18	*8.18	*6.70	6.44					*5.68	5.51	6.71	
	F-Outrigger + R-Outrigger	*10.73	*10.73	*12.44	*12.44	*10.01	*10.01	*8.18	*8.18	*6.70	6.50					*5.68	5.56	6.71	
-4	F-Dozer + R-Outrigger			*10.26	*10.26	*8.40	*8.40	*6.83	*6.83							*5.54	*5.54	5.82	
	F-Outrigger + R-Outrigger			*10.26	*10.26	*8.40	*8.40	*6.83	*6.83							*5.54	*5.54	5.82	

Feet

Unit : 1,000lb

A(ft) B(ft)	Classis Frame Attachment	10		15		20		25		Max. Reach				
												A(ft)		
25	F-Dozer + R-Outrigger										*11.68	*11.68	19.87	
	F-Outrigger + R-Outrigger										*11.68	*11.68	19.87	
20	F-Dozer + R-Outrigger					*11.50	*11.50				*11.29	*11.29	23.69	
	F-Outrigger + R-Outrigger					*11.50	*11.50				*11.29	*11.29	23.69	
15	F-Dozer + R-Outrigger					*14.45	*14.45	*12.53	*12.53	*11.55	10.59	*11.45	9.96	25.99
	F-Outrigger + R-Outrigger					*14.45	*14.45	*12.53	*12.53	*11.55	10.68	*11.45	10.06	25.99
10	F-Dozer + R-Outrigger	*19.62	*19.62	*18.12	*18.12	*14.16	*14.16	*12.17	10.43	*11.62	9.21	*11.62	9.21	27.18
	F-Outrigger + R-Outrigger	*19.62	*19.62	*18.12	*18.12	*14.16	*14.16	*12.17	10.53	*11.62	9.29	*11.62	9.29	27.18
5	F-Dozer + R-Outrigger	*5.52	*5.52	*21.33	*21.33	*15.73	14.18	*12.85	10.26	*11.87	8.99	*11.87	8.99	27.40
	F-Outrigger + R-Outrigger	*5.52	*5.52	*21.33	*21.33	*15.73	14.31	*12.85	10.35	*11.87	9.08	*11.87	9.08	27.40
0 (GND)	F-Dozer + R-Outrigger	*10.83	*10.83	*22.69	*22.69	*16.62	13.91	*13.12	10.13	*12.16	9.26	*12.16	9.26	26.67
	F-Outrigger + R-Outrigger	*10.83	*10.83	*22.69	*22.69	*16.62	14.04	*13.12	10.22	*12.16	9.35	*12.16	9.35	26.67
-5	F-Dozer + R-Outrigger	*20.06	*20.06	*22.09	*22.09	*16.37	13.80			*12.43	10.15	*12.43	10.15	24.92
	F-Outrigger + R-Outrigger	*20.06	*20.06	*22.09	*22.09	*16.37	13.93			*12.43	10.24	*12.43	10.24	24.92
-10	F-Dozer + R-Outrigger	*26.93	*26.93	*19.52	*19.52	*14.36	13.89			*12.51	12.24	*12.51	12.24	21.90
	F-Outrigger + R-Outrigger	*26.93	*26.93	*19.52	*19.52	*14.36	14.02			*12.51	12.35	*12.51	12.35	21.90
-15	F-Dozer + R-Outrigger			*13.74	*13.74					*11.69	*11.69	*11.69	*11.69	16.90
	F-Outrigger + R-Outrigger			*13.74	*13.74					*11.69	*11.69	*11.69	*11.69	16.90

- Ratings are based on SAE J1097
- Load point is the end of arm.
- * Rated loads are based on hydraulic capacity.
- Rated loads do not exceed 87% of hydraulic capacity or 75% of tipping capacity.

: Rating Over Front
 : Rating Over Side or 360 Degree

LIFTING CAPACITY

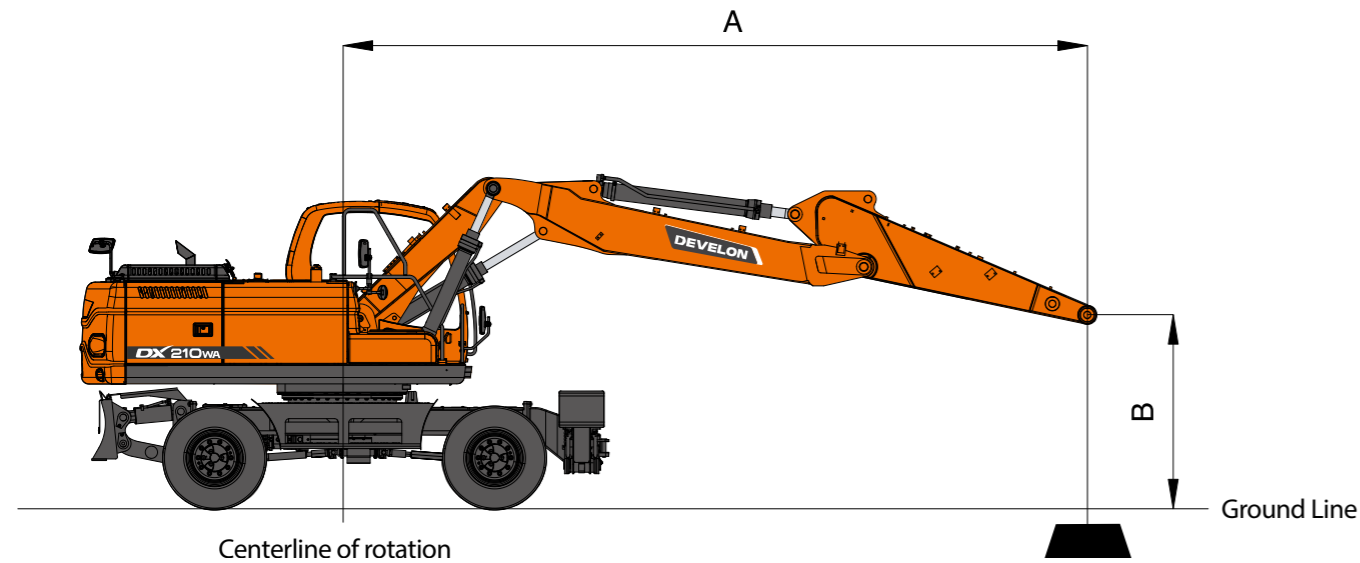

OPTION 3

Boom : 5.4 m (17'08") Two-Piece Boom Arm : 2.4 m (7'10") Bucket : Without Bucket Counterweight : 3,800 kg

Metric

Unit : 1,000kg

A(m) B(m)	Classis Frame Attachment	2		3		4		5		6		7		Max. Reach						
		☺	☹	☺	☹	☺	☹	☺	☹	☺	☹	☺	☹	☺	☹	A(m)				
8	F-Dozer + R-Outrigger														*6.20	*6.20	4.81			
	F-Outrigger + R-Outrigger														*6.20	*6.20	4.81			
7	F-Dozer + R-Outrigger							*5.88	*5.88						*5.87	4.85	5.89			
	F-Outrigger + R-Outrigger							*5.88	*5.88						*5.87	*5.87	5.89			
6	F-Dozer + R-Outrigger							*6.07	*6.07	*5.80	4.72				*5.74	4.02	6.64			
	F-Outrigger + R-Outrigger							*6.07	*6.07	*5.80	*5.80				*5.74	5.74	6.64			
5	F-Dozer + R-Outrigger					*7.51	*7.51	*6.60	6.12	*6.04	4.66	*5.73	3.69	*5.70	3.55	7.17				
	F-Outrigger + R-Outrigger					*7.51	*7.51	*6.60	*6.60	*6.04	*6.04	*5.73	5.26	*5.70	5.06	7.17				
4	F-Dozer + R-Outrigger					*12.32	*12.32	*8.92	*8.92	*7.35	5.96	*6.45	4.57	*5.90	3.65	*5.71	3.27	7.53		
	F-Outrigger + R-Outrigger					*12.32	*12.32	*8.92	*8.92	*7.35	*7.35	*6.45	*6.45	*5.90	5.22	*5.71	4.67	7.53		
3	F-Dozer + R-Outrigger							*10.45	7.97	*8.18	5.78	*6.93	4.47	*6.15	3.59	*5.75	3.10	7.74		
	F-Outrigger + R-Outrigger							*10.45	*10.45	*8.18	*8.18	*6.93	6.49	*6.15	5.16	*5.75	4.44	7.74		
2	F-Dozer + R-Outrigger							*10.27	7.70	*8.89	5.62	*7.36	4.37	*6.39	3.54	*5.81	3.03	7.82		
	F-Outrigger + R-Outrigger							*10.27	*10.27	*8.89	8.42	*7.36	6.39	*6.39	5.10	*5.81	4.34	7.82		
1	F-Dozer + R-Outrigger							*9.00	7.56	*8.99	5.51	*7.66	4.30	*6.55	3.49	*5.89	3.03	7.76		
	F-Outrigger + R-Outrigger							*9.00	*9.00	*9.32	8.29	*7.66	6.30	*6.55	5.04	*5.89	4.36	7.76		
0	F-Dozer + R-Outrigger							*2.96	*2.96	*11.08	7.51	*9.41	5.45	*7.75	4.25	*6.55	3.46	*5.96	3.12	7.57
	F-Outrigger + R-Outrigger							*2.96	*2.96	*11.08	*11.08	*9.41	8.22	*7.75	6.25	*6.55	5.01	*5.96	4.50	7.57
-1	F-Dozer + R-Outrigger							*7.40	*7.40	*11.30	7.51	*9.18	5.43	*7.58	4.23	*6.31	3.45	*6.02	3.31	7.23
	F-Outrigger + R-Outrigger							*7.40	*7.40	*11.30	*11.30	*9.18	8.20	*7.58	6.23	*6.31	5.01	*6.02	4.79	7.23
-2	F-Dozer + R-Outrigger	*8.47	*8.47	*12.13	*12.13	*10.43	7.56	*8.59	5.45	*7.07	4.24				*6.03	3.66	6.73			
	F-Outrigger + R-Outrigger	*8.47	*8.47	*12.13	*12.13	*10.43	*10.43	*8.59	8.22	*7.07	6.24				*6.03	5.31	6.73			

Feet

Unit : 1,000lb

A(ft) B(ft)	Classis Frame Attachment	10		15		20		25		Max. Reach				
		☺	☹	☺	☹	☺	☹	☺	☹	☺	☹	A(ft)		
25	F-Dozer + R-Outrigger											*13.31	12.69	17.30
	F-Outrigger + R-Outrigger											*13.31	*13.31	17.30
20	F-Dozer + R-Outrigger							*12.74	10.15			*12.68	9.00	21.59
	F-Outrigger + R-Outrigger							*12.74	*12.74			*12.68	*12.68	21.59
15	F-Dozer + R-Outrigger	*22.43	*22.43	*16.15	15.28	*13.57	9.96					*12.57	7.52	24.09
	F-Outrigger + R-Outrigger	*22.43	*22.43	*16.15	*16.15	*13.57	*13.57					*12.57	10.73	24.09
10	F-Dozer + R-Outrigger					*19.67	14.50	*15.03	9.65	*12.79	7.01	*12.68	6.86	25.37
	F-Outrigger + R-Outrigger					*19.67	*19.67	*15.03	13.99	*12.79	10.03	*12.68	9.81	25.37
5	F-Dozer + R-Outrigger					*22.29	13.88	*16.32	9.35	*13.19	6.89	*12.89	6.66	25.61
	F-Outrigger + R-Outrigger					*22.29	21.20	*16.32	13.66	*13.19	9.90	*12.89	9.56	25.61
0 (GND)	F-Dozer + R-Outrigger	*7.27	*7.27	*22.80	13.62	*16.80	9.17					*13.14	6.88	24.83
	F-Outrigger + R-Outrigger	*7.27	*7.27	*22.80	20.90	*16.80	13.46					*13.14	9.91	24.83
-5	F-Dozer + R-Outrigger	*22.07	*22.07	*21.40	13.61	*15.95	9.14					*13.30	7.65	22.94
	F-Outrigger + R-Outrigger	*22.07	*22.07	*21.40	20.89	*15.95	13.42					*13.30	11.08	22.94
-10	F-Dozer + R-Outrigger	*23.55	*23.55	*17.87	13.81							*13.04	9.56	19.60
	F-Outrigger + R-Outrigger	*23.55	*23.55	*17.87	*17.87							*13.04	*13.04	19.60

1. Ratings are based on SAE J1097
2. Load point is the end of arm.
3. * Rated loads are based on hydraulic capacity.
4. Rated loads do not exceed 87% of hydraulic capacity or 75% of tipping capacity.

☺ : Rating Over Front
☹ : Rating Over Side or 360 Degree

LIFTING CAPACITY

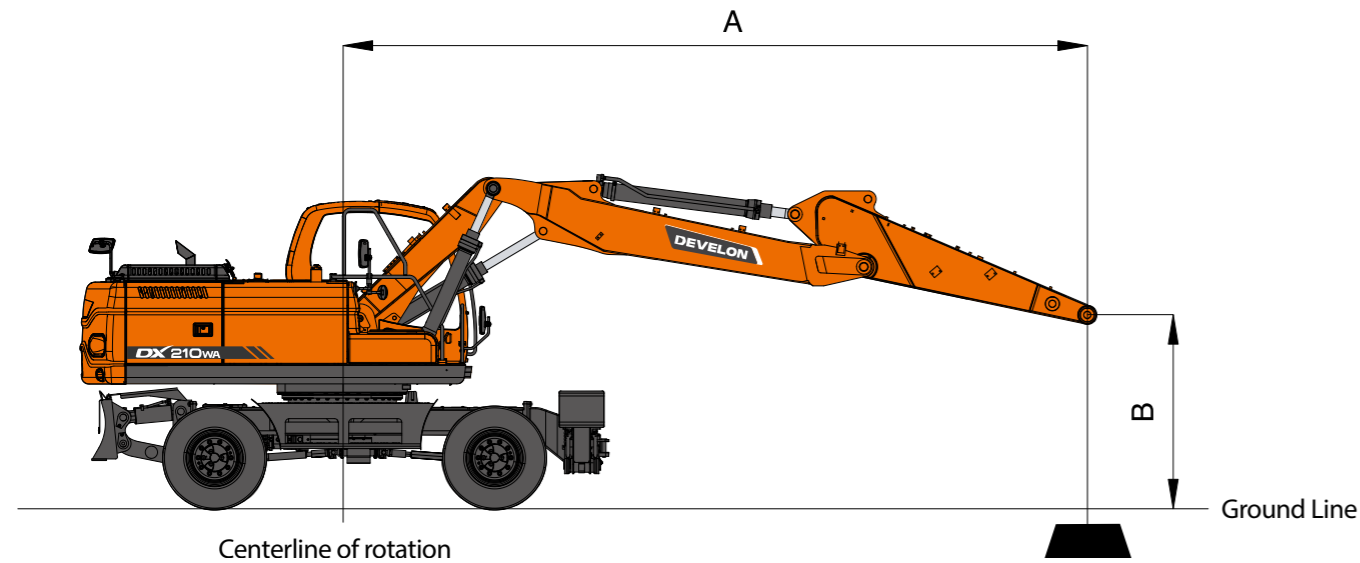

OPTION 4

Boom : 5.4 m (17'08") Two-Piece Boom Arm : 2.0 m (6'07") Bucket : Without Bucket Counterweight : 3,800 kg

Metric

Unit : 1,000kg

A(m) B(m)	Classis Frame Attachment	3		4		5		6		7		Max. Reach		A(m)
7	F-Dozer + R-Outrigger					*6.37	6.14					*6.35	5.44	5.40
	F-Outrigger + R-Outrigger					*6.37	*6.37					*6.35	*6.35	5.40
6	F-Dozer + R-Outrigger					*6.49	6.11	*6.17	4.61			*6.15	4.36	6.21
	F-Outrigger + R-Outrigger					*6.49	*6.49	*6.17	*6.17			*6.15	*6.15	6.21
5	F-Dozer + R-Outrigger	*10.28	*10.28	*8.11	*8.11	*6.99	6.00	*6.34	4.56			*6.07	3.79	6.77
	F-Outrigger + R-Outrigger	*10.28	*10.28	*8.11	*8.11	*6.99	*6.99	*6.34	*6.34			*6.07	5.43	6.77
4	F-Dozer + R-Outrigger			*9.57	8.12	*7.73	5.84	*6.71	4.49	*6.12	3.58	*6.06	3.46	7.15
	F-Outrigger + R-Outrigger			*9.57	*9.57	*7.73	*7.73	*6.71	6.49	*6.12	5.13	*6.06	4.96	7.15
3	F-Dozer + R-Outrigger			*11.07	7.79	*8.51	5.68	*7.15	4.39	*6.31	3.53	*6.09	3.27	7.37
	F-Outrigger + R-Outrigger			*11.07	*11.07	*8.51	8.46	*7.15	6.39	*6.31	5.08	*6.09	4.70	7.37
2	F-Dozer + R-Outrigger			*5.60	*5.60	*9.12	5.54	*7.52	4.31	*6.50	3.48	*6.14	3.19	7.45
	F-Outrigger + R-Outrigger			*5.60	*5.60	*9.12	8.30	*7.52	6.30	*6.50	5.03	*6.14	4.59	7.45
1	F-Dozer + R-Outrigger			*6.49	*6.49	*9.42	5.45	*7.74	4.25	*6.58	3.45	*6.20	3.20	7.39
	F-Outrigger + R-Outrigger			*6.49	*6.49	*9.42	8.20	*7.74	6.23	*6.58	4.99	*6.20	4.61	7.39
0	F-Dozer + R-Outrigger			*10.27	7.48	*9.38	5.41	*7.73	4.21	*6.49	3.43	*6.26	3.31	7.19
	F-Outrigger + R-Outrigger			*10.27	*10.27	*9.38	8.15	*7.73	6.19	*6.49	4.97	*6.26	4.78	7.19
-1	F-Dozer + R-Outrigger	*7.06	*7.06	*10.90	7.51	*9.00	5.41	*7.44	4.21			*6.29	3.54	6.84
	F-Outrigger + R-Outrigger	*7.06	*7.06	*10.90	*10.90	*9.00	8.15	*7.44	6.18			*6.29	5.14	6.84
-2	F-Dozer + R-Outrigger	*11.43	*11.43	*9.89	7.56	*8.24	5.44	*6.73	4.24			*6.24	3.97	6.30
	F-Outrigger + R-Outrigger	*11.43	*11.43	*9.89	*9.89	*8.24	8.18	*6.73	6.22			*6.24	5.80	6.30

Feet

Unit : 1,000lb

A(ft) B(ft)	Classis Frame Attachment	10		15		20		Max. Reach		A(ft)		
25	F-Dozer + R-Outrigger					*14.58	*14.58			*14.59	*14.59	15.46
	F-Outrigger + R-Outrigger					*14.58	*14.58			*14.59	*14.59	15.46
20	F-Dozer + R-Outrigger					*14.68	*14.68	*13.59	9.91	*13.59	9.79	20.15
	F-Outrigger + R-Outrigger					*14.68	*14.68	*13.59	*13.59	*13.59	*13.59	20.15
15	F-Dozer + R-Outrigger	*25.33	*25.33	*17.16	14.95	*14.18	9.76	*13.37	8.00	*13.37	8.00	22.82
	F-Outrigger + R-Outrigger	*25.33	*25.33	*17.16	*17.16	*14.18	14.08	*13.37	11.46	*13.37	11.46	22.82
10	F-Dozer + R-Outrigger			*20.58	14.23	*15.50	9.48	*13.42	7.23	*13.42	7.23	24.17
	F-Outrigger + R-Outrigger			*20.58	*20.58	*15.50	13.77	*13.42	10.38	*13.42	10.38	24.17
5	F-Dozer + R-Outrigger			*22.73	13.71	*16.59	9.23	*13.60	7.02	*13.60	7.02	24.42
	F-Outrigger + R-Outrigger			*22.73	20.94	*16.59	13.49	*13.60	10.11	*13.60	10.11	24.42
0 (GND)	F-Dozer + R-Outrigger			*22.62	13.54	*16.76	9.09	*13.79	7.29	*13.79	7.29	23.60
	F-Outrigger + R-Outrigger			*22.62	20.74	*16.76	13.33	*13.79	10.54	*13.79	10.54	23.60
-5	F-Dozer + R-Outrigger	*23.55	*23.55	*20.69	13.58	*15.43	9.10	*13.84	8.23	*13.84	8.23	21.60
	F-Outrigger + R-Outrigger	*23.55	*23.55	*20.69	*20.69	*15.43	13.35	*13.84	11.97	*13.84	11.97	21.60
-10	F-Dozer + R-Outrigger	*20.92	*20.92	*16.42	13.82			*13.20	10.72	*13.20	10.72	18.00
	F-Outrigger + R-Outrigger	*20.92	*20.92	*16.42	*16.42			*13.20	*13.20	*13.20	*13.20	18.00

1. Ratings are based on SAE J1097
2. Load point is the end of arm.
3. * Rated loads are based on hydraulic capacity.
4. Rated loads do not exceed 87% of hydraulic capacity or 75% of tipping capacity.

: Rating Over Front
 : Rating Over Side or 360 Degree

STANDARD & OPTION

STANDARD EQUIPMENT

Hydraulic system

- Boom and arm flow regeneration
- Boom and arm holding valves
- Swing anti-rebound valves
- Spare ports (valve)
- One-touch power boost

Cabin & Interior

- Viscous cab mounts
- All weather sound suppressed type cab
- Air conditioner
- Adjustable suspension seat with head rest and adjustable arm rest
- Pull-up type front window and removable lower front window
- Room light
- Intermittent windshield wiper
- Cigarette lighter and ashtray
- Cup holder
- Hot & Cool box
- LCD color monitor panel
- Engine speed (RPM) control dial
- AM/FM radio and cassette player
- Remote radio ON/OFF switch
- 12V spare powers socket
- Serial communication port for laptop PC interface
- Joystick lever with 3 switches
- Sunvisor
- Sun roof
- wiper

Safety

- Large handrails and step
- Punched metal anti-slip plates
- Seat belt
- Hydraulic safety lock lever
- Safety glass
- Hammer for emergency escape
- Right and left rearview mirrors
- Reverse travel alarm
- Emergency engine stop
- LED stop lamps

Others

- Double element air cleaner
- Fuel pre-filter
- Dust screen for radiator/oil cooler/charged air cooler
- Engine overheat prevention system
- Engine restart prevention system
- Self-diagnostic system
- Large capacity alternator (24V, 60 amps)
- Electric horn
- Halogen working lights (frame mounted 2, boom mounted 2)
- 3.8ton counter weightUndercarriage
- 10.0-20-16PR double tires
- Heavy duty axles
- Parallel dozer blade & individually controlled outriggers
- Tool box
- Front axle oscillation auto lock

OPTIONAL EQUIPMENT

Some of these optional equipments may be standard in some markets. Some of these optional equipments cannot be available on some markets. You must check with the local Develon dealer to know about the availability or to release the adaptation following the needs of the applications.

Safety

- Boom and arm hose rupture protection valve
- Overload warning device
- Cabin Top/Front guard (ISO 10262, FOGS standard)
- Travel & swing alarm
- Rotation beacon
- Mirror & Lamp on counter weight
- Rear View Camera

Cabin & Interior

- Air suspension seat
- MP3/CD player
- Rain shield
- 2 front lamps
- 4 front + 2 rear lamps

Others

- Piping for crusher
- Piping for quick clamp
- Piping for front attachment rotation
- Breaker filter
- Lower wiper
- Fuel heater
- Fuel filler pump

Undercarriage

- 10.0-20-14PR double tire